

Marine Projects Ltd.
Newport Street, Plymouth, Devon. PL1 3QG.

KEY TO FITTINGS

- A BREATHER, 25 mm OD. WITH 90° ELBOW
OA. LENGTH 75 mm
- B SUCTION. 3/8" BSP BARREL SOCKET WITH
22 mm Ø DOWNPIPE 725mm LONG.
90° ELBOW WITH SUPPLY TAP.
- C SUCTION. - 3/8" BSP
BARREL SOCKET WITH 22 mm Ø DOWNPIPE
725mm LONG. - 90° ELBOW.
- D FILLER. 50 mm OD. - 90° ELBOW;
LENGTH 805mm FROM TOP OF UPSTAND.
- E SENDER: WEMA; 654967.
- F INSPECTION HATCH. STANDARD 267 mm
SQUARE HATCH. BOLTED DOWN ON
NEOPRENE GASKET WITH M10 BOLTS.
- G SUCTION - CENTRAL HEATING.
3/8" BSP BARREL SOCKET WITH
22mm DOWNPIPE 725mm LONG.

NOTES

MATERIAL: 3mm ALUMINIUM NS4
CAPACITY= 218 LITRES (48 GALLONS)
ALL DIMENSIONS IN mm
SUCTION DOWNPIPE LENGTHS EXCLUDE SOCKETS

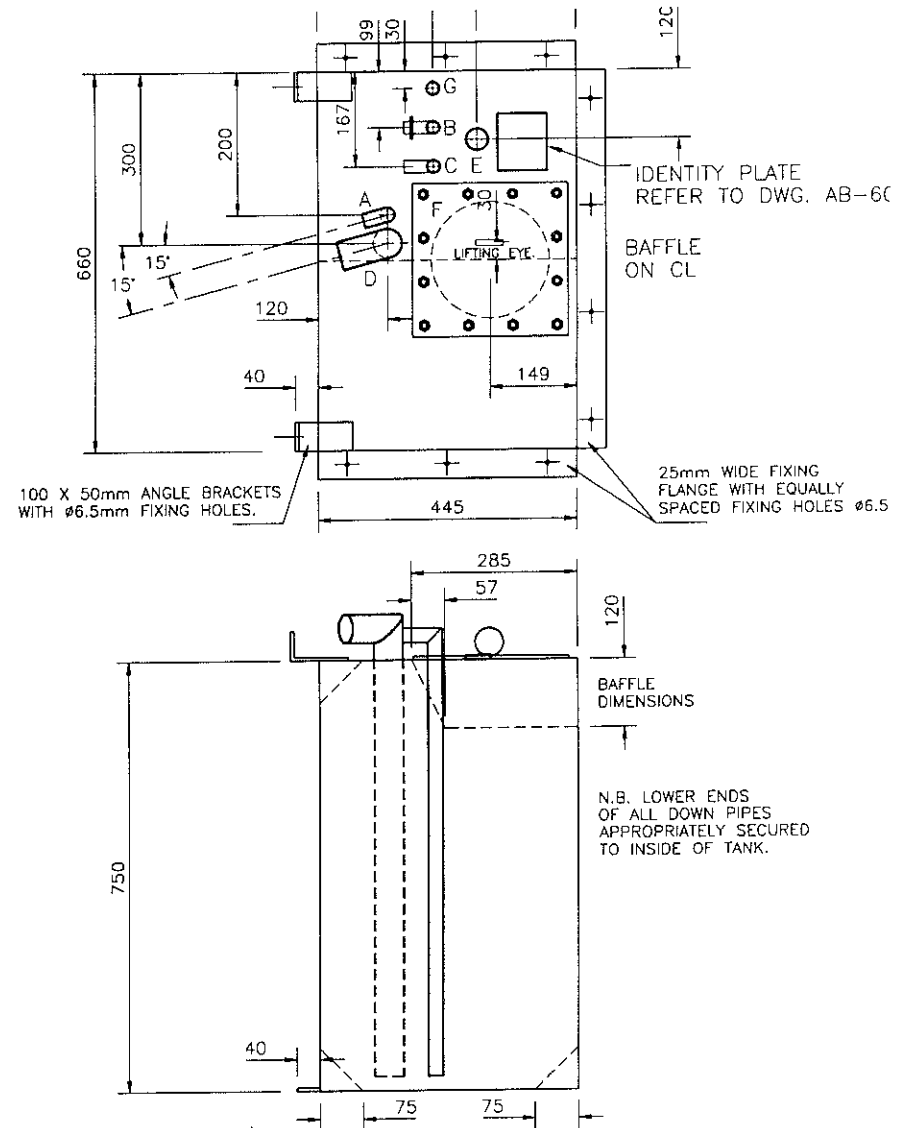

REDUCE FIXING BRACKETS TO EXTEND 40 mm FROM EDGE, NOT 50 mm	E	K.B.K	20.1.97	ET	PC.7636
BREATHER PIPE MOVED STARBOARD OF FILLER BY 30mm. FIXING FLANGE WAS 50mm WIDE NOW 25mm.	D	ET.	31.10.96	K.B.K	PC 6917 PC 7021
WIDTH & LENGTH OF TANK CHANGED. FITTINGS A,B & C MOVED. FITTING G ADDED. CAPACITY CHANGED. LIFTING EYE ADDED TO HATCH.	C	E.T	26.7.96	K.B.K	PC 6731
IDENTITY PLATE ADDED	B	E.T	10.7.96	MHR	PC 6271
MODIFICATION	ISSUE A	CHECKED BY	DATE	DRAWN BY	CHANGE REF

TITLE G6 FUEL TANK

	INITIALS	DATE	SCALE	DRAWING NUMBER
DRAWN BY	JWDW	22/3/96	N.T.S.	G6-438
CHECKED BY	KBK	1/4/96		

Marine Projects Ltd.
Newport Street, Plymouth, Devon. PL1 3QG.

KEY TO FITTINGS

- A BREATHER. 25 mm OD. WITH 90° ELBOW
OA. LENGTH 75 mm
- B SUCTION. 3/8" BSP BARREL SOCKET WITH
22 mm Ø DOWNPIPE 725mm LONG.
90° ELBOW WITH SUPPLY TAP.
- C SUCTION. - 3/8" BSP
BARREL SOCKET WITH 22 mm Ø DOWNPIPE
725mm LONG. - 90° ELBOW.
- D FILLER. 50 mm OD. - 90° ELBOW;
LENGTH 805mm FROM TOP OF UPSTAND.
- E SENDER: WEMA; 654967.
- F INSPECTION HATCH. STANDARD 267 mm
SQUARE HATCH. BOLTED DOWN ON
NEOPRENE GASKET WITH M10 BOLTS.
- G SUCTION - CENTRAL HEATING.
3/8" BSP BARREL SOCKET WITH
22mm DOWNPIPE 725mm LONG.

NOTES

MATERIAL: 3mm ALUMINIUM NS4
CAPACITY= 218 LITRES (48 GALLONS)
ALL DIMENSIONS IN mm
SUCTION DOWNPIPE LENGTHS EXCLUDE SOCKETS

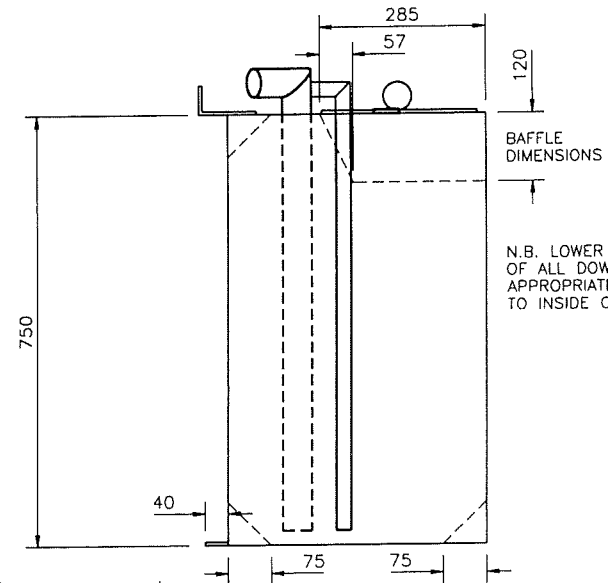
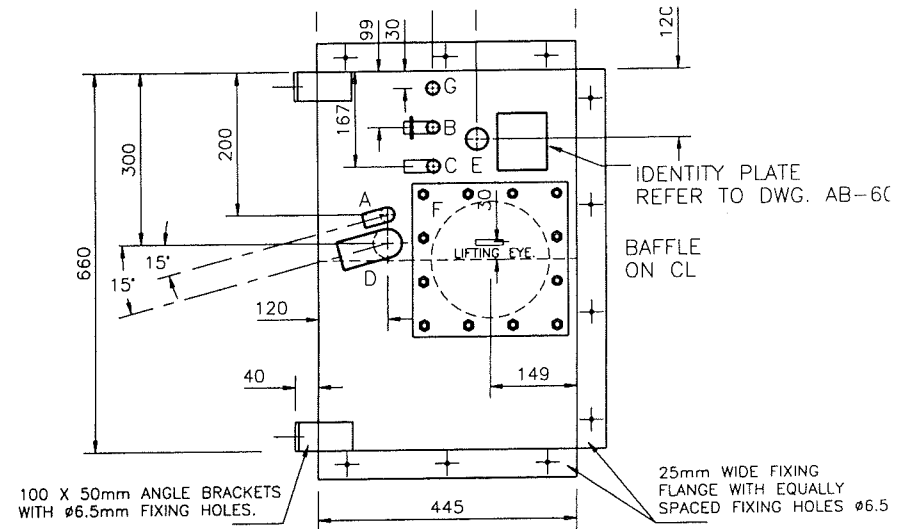

REDUCE FIXING BRACKETS TO EXTEND 40 mm FROM EDGE, NOT 50 mm	E	K.B.K	20.1.97	ET	PC.7636
BREATHER PIPE MOVED STARBOARD OF FILLER BY 30mm. FIXING FLANGE WAS 50mm WIDE NOW 25mm.	D	ET.	31.10.96	K.B.K	PC 6917 PC 7021
WIDTH & LENGTH OF TANK CHANGED. FITTINGS A,B & C MOVED. FITTING G ADDED. CAPACITY CHANGED. LIFTING EYE ADDED TO HATCH.	C	E.T	26.7.96	K.B.K	PC 6731
IDENTITY PLATE ADDED	B	E.T	10.7.96	MHR	PC 6271
<u>MODIFICATION</u>	ISSUE A	CHECKED BY	DATE	DRAWN BY	CHANGE REF

TITLE G6 FUEL TANK

	INITIALS	DATE	SCALE	DRAWING NUMBER
DRAWN BY	JWDW	22/3/96	N.T.S.	G6-438
CHECKED BY	KBK	1/4/96		