

- FITTINGS :**
- Ⓐ BREATHER PIPE - $\phi 25$, 90° ELBOW 75mm LONG.
 - Ⓑ BALANCE PIPE - $\phi 22$, BARTOL FITTING.
 - Ⓒ HOLDING LUGS - 9mm POLYPROPELENE, $\phi 6$ mm IN CENTRAL POSITION 10 mm FROM THE TOP.

MATERIAL :
 BODY - 12mm POLYPROPELENE
 BAFFLES & STIFFENERS - 9mm POLYPROPELENE

CAPACITY :
 30 GALLONS / 136 LITRES

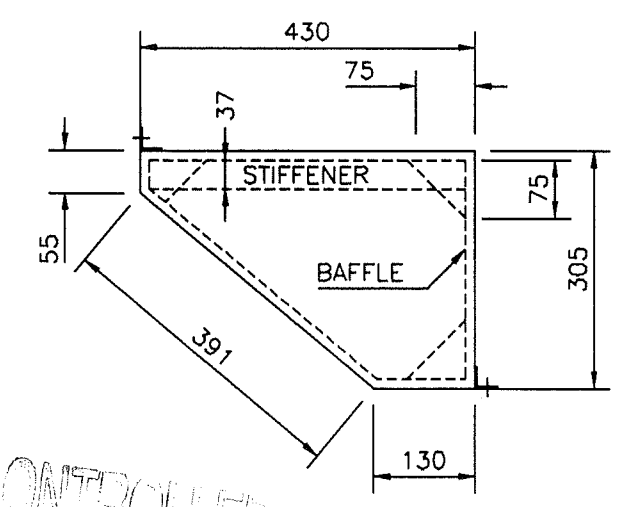
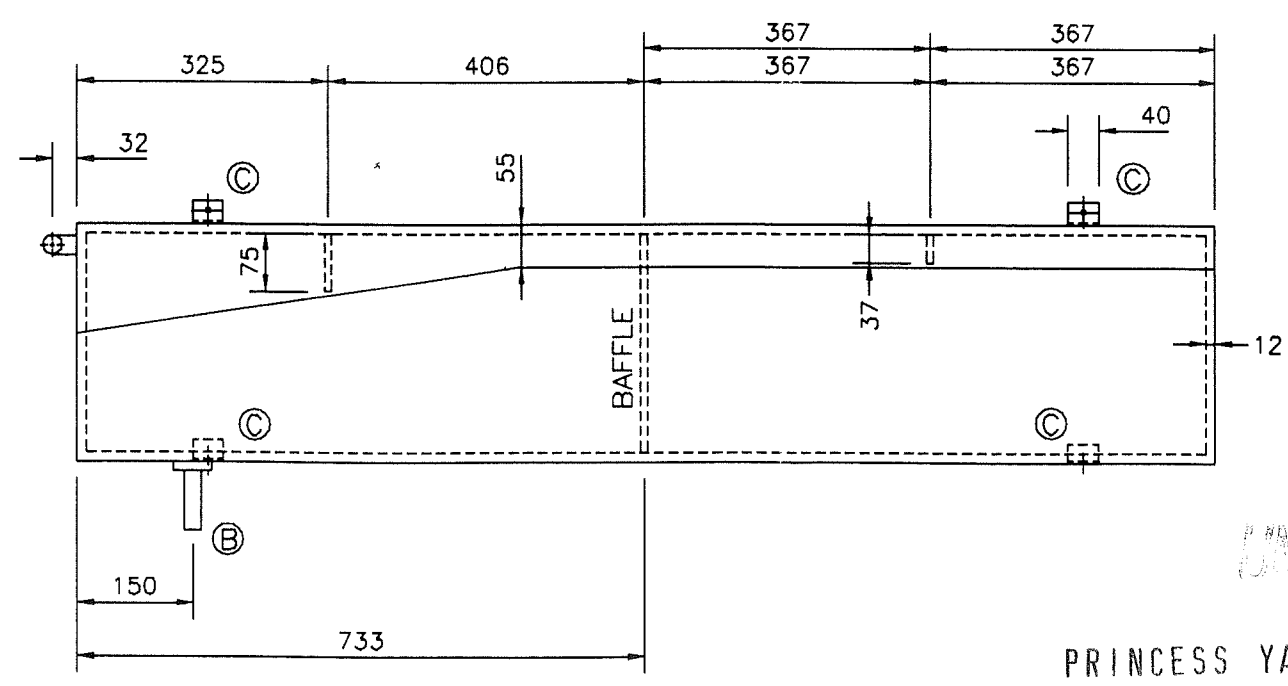
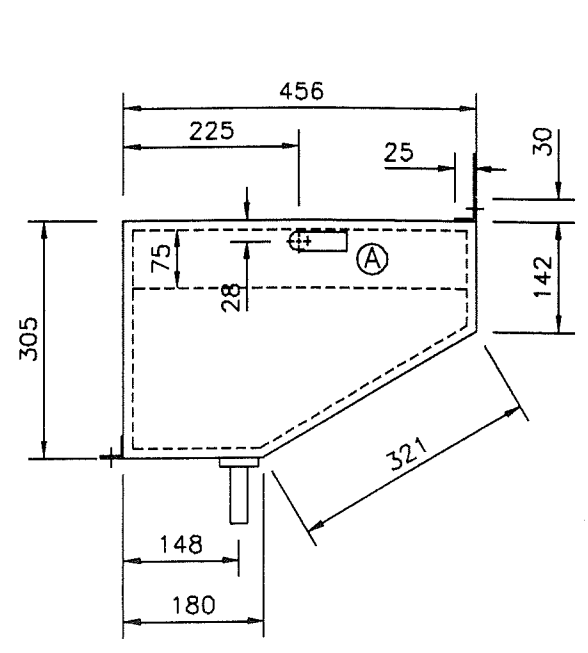

UNCONTROLLED

PRINCESS YACHTS

03 SEP 2002

INTERNATIONAL PLC FOR PORT TANK REFER TO DRAWING No.G6-436.
 TO BE READ IN CONJUNCTION WITH DWG No. G6-580.

MATERIAL CHANGED FROM ALUMINIUM TO 9mm POLYPROPELENE.	E	←	27/10/99	MHR	PC 11516					
ADDED HOLDING LUGS	D	MHR	20.02.97	CMV	PC7548					
I.D. PLATE POSITION SHOWN.	C	ET	19.09.96	JRD	PC6575					
DIMENSION 1466 mm MOVED TO NEW LOCATION	B	JWDW	17.04.96	MHR	PC6179					
Marine Projects Ltd. Newport Street, Plymouth, Devon. PL1 3QG.	MODIFICATION					ISSUE A	CHECKED BY	DATE	DRAWN BY	CHANGE REF
TITLE G6 STARBOARD WATER TANK.										
						DRAWN BY	INITIALS	DATE	SCALE	DRAWING NUMBER
						CHECKED BY	J.W.	17.04.96	N.T.S.	G6-435